



**MANGAL JOSPER MGJ-132**  
**MANGAL JOSPER MGJ-132**



# MGJ-132

At Josper we have embraced the Middle East culinary tradition and have applied the latest technology to it in order to create the Josper Mangal, an open wood charcoal grill to cook using the Mangal style. Josper's Mangal is a multifunctional open grill due to three key factors: an extra-large grilling area, four braising levels and a set of accessories that allow all kind of gastronomic applications.

En Josper hemos recogido la tradición culinaria de Oriente Medio y le hemos aplicado la última tecnología en brasa. El Mangal Josper, la parrilla abierta de carbón vegetal para cocinar al estilo mangal, es ideal por su multifuncionalidad gracias a tres factores clave: superficie de parrilla formato extra grande, cuatro niveles de braseado y accesorios conjugados que permiten todo tipo de aplicaciones.

MGJ-132



Braising area Superficie de braseado	48 5/8 x 19 1/4 in (x4) 1235 x 490 mm (x4)
Fire up time Tiempo de encendido	20 min average 20 min aprox.
Charcoal daily consumption Consumo diario de carbón	48.5 to 53 lb 22 a 24kg
Broiling temperature Temperatura de braseado	482 °F 250 °C
Exhaust rate Capacidad de extracción	4000 m³/h 4000 m³/h
Net weight Peso neto	2563.98 lb 1163 kg

## INCLUDED ACCESORIES

### ACCESORIOS INCLUIDOS

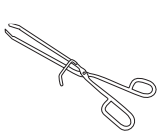

Josper tongs / Ref. [0423](#)  
 Pinzas Josper / Ref. [0423](#)

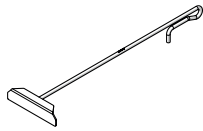

Poker / Ref. [0427INOX](#)  
 Atizador / Ref. [0427INOX](#)

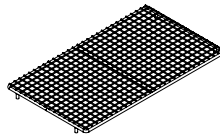

Temperer grill rack / Ref. [260006](#)  
 Rejilla atemperadora / Ref. [260006](#)

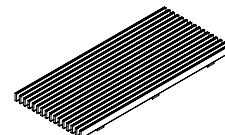

Metallic grill rack / Ref. [260007](#)  
 Parrilla metálica / Ref. [260007](#)

\* All Josper products work exclusively with charcoal.  
 Todos los productos Josper funcionan exclusivamente con carbón vegetal.

\* The NSF certification refers to the equipment and not to the accessories described in this document.  
 La certificación NSF hace referencia exclusivamente a los equipos y no a los accesorios descritos en este documento.





**JOSPER TECHNOLOGY**  
 TECNOLOGÍA JOSPER

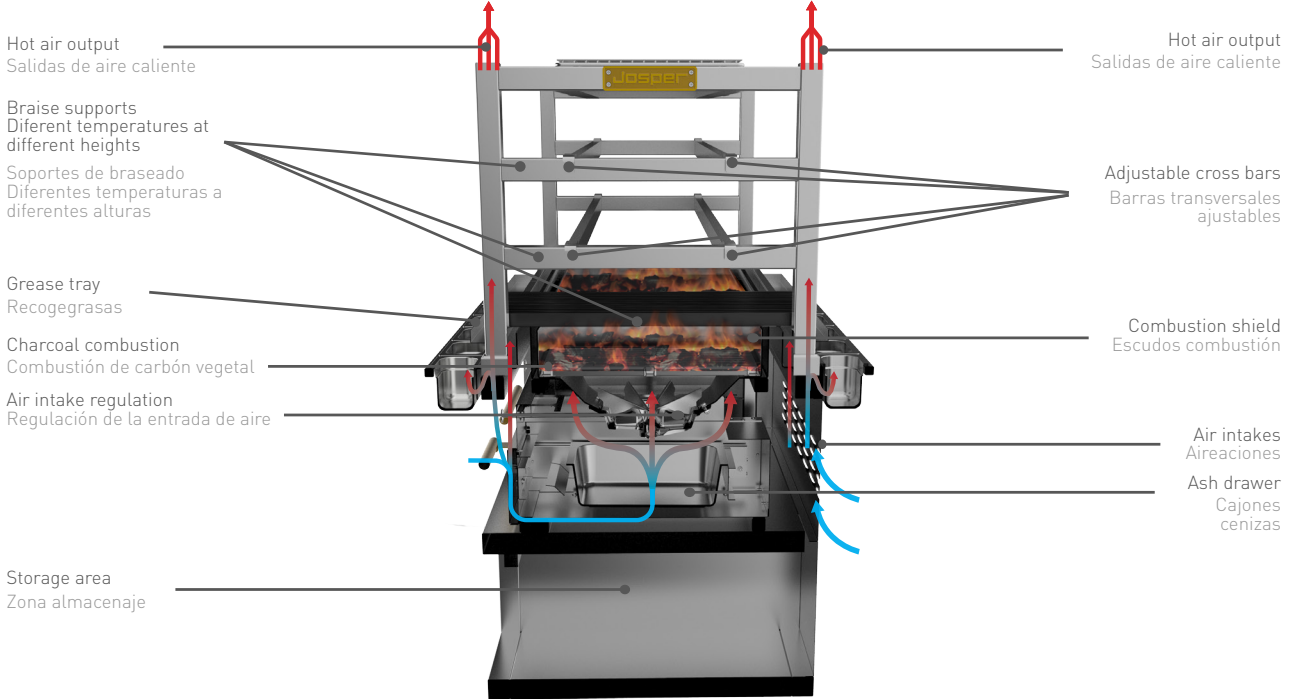

**INSTALLATION**  
 INSTALACIÓN

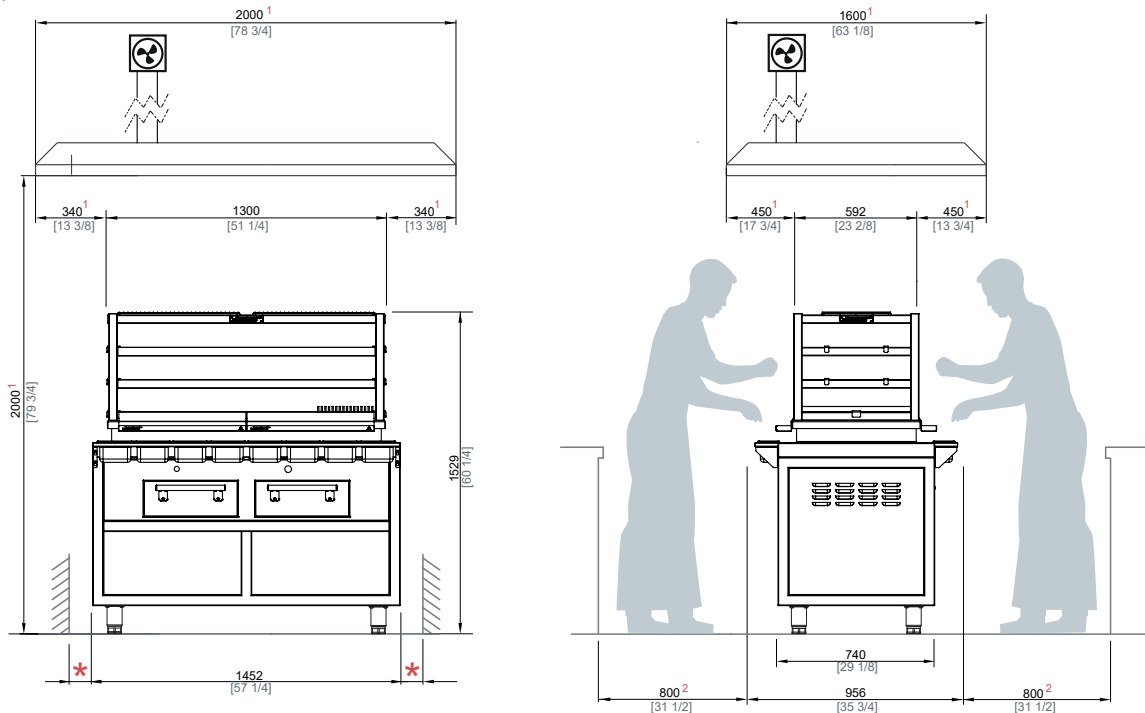

* MINIMUM DISTANCE TO FLAMMABLE ELEMENTS DISTANCIA MÍNIMA A ELEMENTOS INFLAMABLES	19 3/4 in	500 mm
* MINIMUM DISTANCE TO NON FLAMMABLE ELEMENTS DISTANCIA MÍNIMA A ELEMENTOS NO INFLAMABLES	4 in	100 mm

- 1 RECOMMENDED HOOD'S MINIMUM DIMENSIONS  
MEDIDAS MÍNIMAS RECOMENDADAS DE LA CAMPANA EXTRACTORA.
- 2 RECOMMENDED CHEF'S WORKING SPACE  
ESPACIO RECOMENDADO DE TRABAJO PARA EL CHEF.
- 3 RECOMMENDED HEIGHT TO INSTALL THE OVEN WITHOUT TABLE  
ALTURA RECOMENDADA DE INSTALACIÓN DEL HORNO SIN MESA.

Ed. 0515 - Jospers reserves the right to make modifications to catalogues, pricelists and promotional material according to the development and improvements applied to its equipment.  
 Jospers se reserva el derecho a realizar modificaciones en los catálogos, tarifas y material de divulgación según evolución y mejora de sus equipos.

