



HJX-PRO-L175-T

Josper is an elegant combination of a grill and an oven in a single machine. It works 100% with charcoal. A unique closed barbecue design. Different levels of grilling. Flexible and robust, easy to use, with a front opening door system. Vent system for temperature control.

Josper es una elegante combinación entre una parrilla y un horno en una sola máquina. Trabaja 100% con carbón vegetal, tiene un diseño único de barbacoa cerrada, con diferentes niveles de braseado, un sistema de puerta frontal, ágil y robusta, de fácil manejo y control de temperatura por un sistema de tiros.

Recommended for ± Recomendado para ±	175 dinners 175 comensales
Fire up time Tiempo de encendido	40 min average 40 min aprox.
Charcoal daily consumption Consumo diario de carbón	17.64 to 22.05 lb 8 a 10 kg
Production per hour Producción por hora	243 lb average 110 kg aprox.
Broiling temperature Temperatura de braseado	482 a 662 °F 250 a 350 °C
Grill rack capacity in Gn trays Capacidad bandejas GN (por parrilla)	2xGN1/1
Flue gas mass flow Caudal másico de humos	0.83 oz/s 23.57 g/s
Exhaust rate Capacidad de extracción	3800 m³/h 3800 m³/h
Net weight Peso neto	914.92 lb 415 kg

HJX-PRO-L175-T



INCLUDED ACCESSORIES ACCESORIOS INCLUIDOS

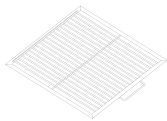

Inox grill rack / Ref. [270090](#)
Parrilla inox / Ref. [270090](#)

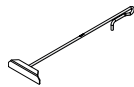

Poker / Ref. [04271NOX](#)
Atizador / Ref. [04271NOX](#)



Josper tongs / Ref. [0423](#)
Pinzas Josper / Ref. [0423](#)

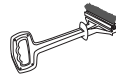

Metallic brush / Ref. [8224](#)
Cepillo metálico / Ref. [8224](#)

GRILL RACK MEASUREMENTS MEDIDAS PARRILLA

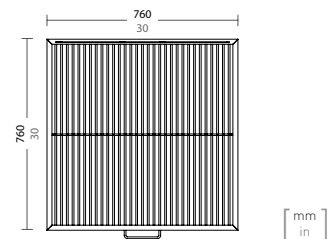

* All Josper products work exclusively with charcoal.
Todos los productos Josper funcionan exclusivamente con carbón vegetal.

* The NSF certification refers to the equipment and not to the accessories described in this document.
La certificación NSF hace referencia exclusivamente a los equipos y no a los accesorios descritos en este documento.

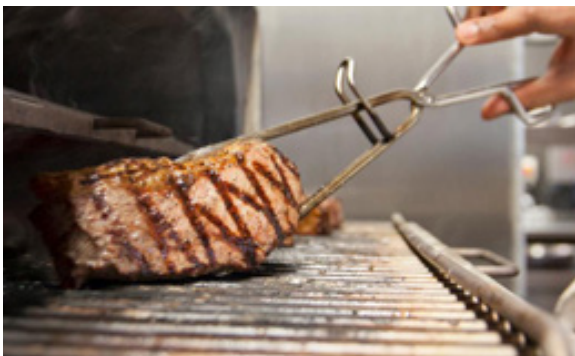



INSTALLATION
 INSTALACIÓN

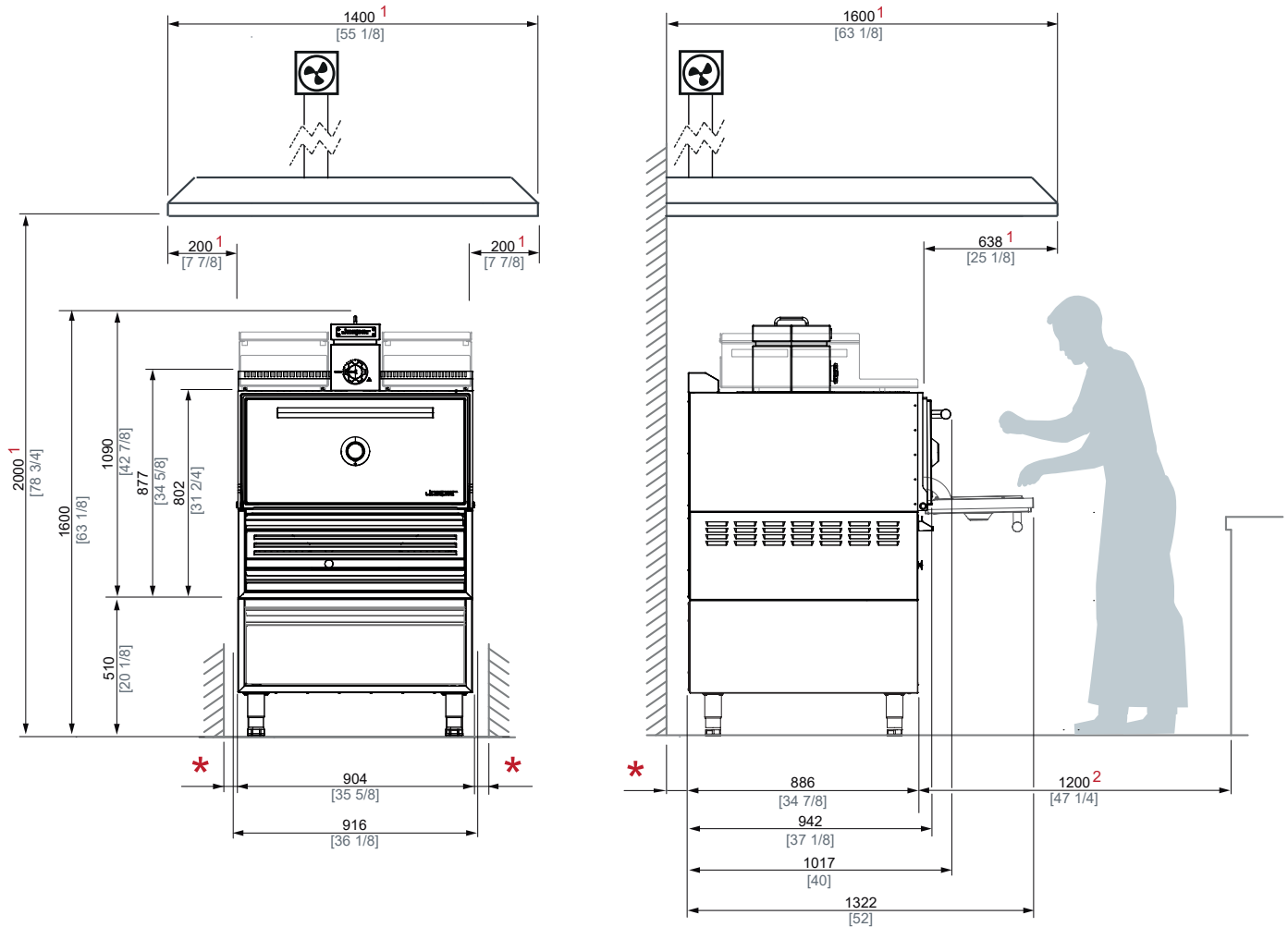

* MINIMUM DISTANCE TO FLAMMABLE ELEMENTS DISTANCIA MÍNIMA A ELEMENTOS INFLAMABLES	12 in	300 mm
* MINIMUM DISTANCE TO NON-FLAMMABLES ELEMENTS DISTANCIA MÍNIMA A ELEMENTOS NO INFLAMABLES	4 in	100 mm

- 1 RECOMMENDED HOOD'S MINIMUM DIMENSIONS
MEDIDAS MÍNIMAS RECOMENDADAS DE LA CAMPANA EXTRACTORA.
- 2 RECOMMENDED CHEF'S WORKING SPACE
ESPACIO RECOMENDADO DE TRABAJO PARA EL CHEF.
- 3 RECOMMENDED HEIGHT TO INSTALL THE OVEN WITHOUT TABLE
ALTURA RECOMENDADA DE INSTALACIÓN DEL HORNO SIN MESA.

Ed. 0517 - Jospser reserves the right to make modifications to catalogues, pricelists and promotional material according to the development and improvements applied to its equipment.
 Jospser se reserva el derecho a realizar modificaciones en los catálogos, tarifas y material de divulgación según evolución y mejora de sus equipos.

