



HJA-PLUS-L175-T

Class A charcoal ovens incorporate a hydraulic door retention system to optimize the chef's maneuvers. They have an upper tempering area that can be closed with the available accessory and a range of optional auxiliary tables.

Los hornos de carbón vegetal Clase A incorporan un sistema hidráulico de retención de puerta para optimizar las maniobras del cocinero. Disponen de una area de templado superior que puede cerrarse con el accesorio disponible y una gama de mesas auxiliares opcionales.

HJA-PLUS-L175-T



Recommended for ± Recomendado para ±	175 dinners 175 comensales
Fire up time Tiempo de encendido	40 min average 40 min aprox.
Charcoal consumption per service Consumo de carbón por servicio	17.63 to 22 lb 8 a 10 kg
Production per hour Producción por hora	242.5 lb average 110 kg aprox.
Broiling temperature Temperatura de braseado	482 a 662 °F 250 a 350 °C
Grill rack capacity in Gn trays Capacidad bandejas GN (por parrilla)	2xGN1/1
Flue gas mass flow Caudal másico de humos	0.83 oz/s 23.57 g/s
Exhaust rate Capacidad de extracción	3800 m³/h 3800 m³/h

INCLUDED ACCESSORIES ACCESORIOS INCLUIDOS

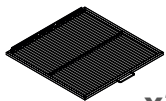

x2

Inox grill rack / Ref. [240026](#)
Parrilla inox / Ref. [240026](#)

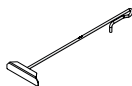

Poker / Ref. [0427INOX](#)
Atizador / Ref. [0427INOX](#)



Jospers tongs / Ref. [0423](#)
Pinzas Jospers / Ref. [0423](#)

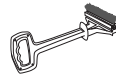

Metallic brush / Ref. [8224](#)
Cepillo metálico / Ref. [8224](#)

GRILL RACK MEASUREMENTS MEDIDAS PARRILLA

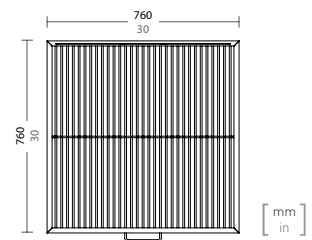

* All Jospers products work exclusively with charcoal.
Todos los productos Jospers funcionan exclusivamente con carbón vegetal.

* The NSF certification refers to the equipment and not to the accessories described in this document.
La certificación NSF hace referencia exclusivamente a los equipos y no a los accesorios descritos en este documento.





INSTALLATION
INSTALACIÓN

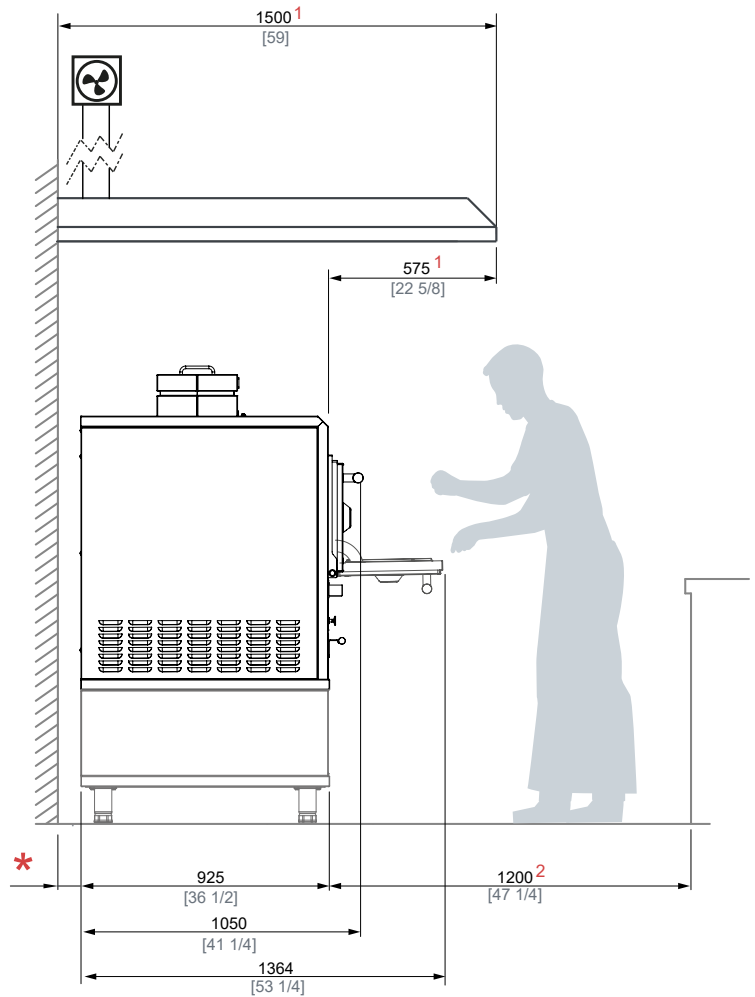
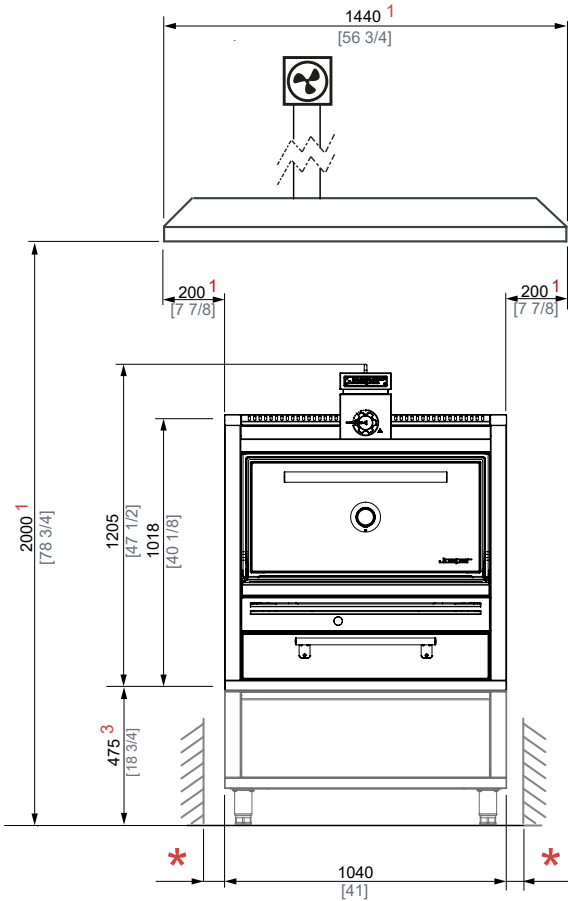

* MINIMUM DISTANCE TO FLAMMABLE ELEMENTS DISTANCIA MÍNIMA A ELEMENTOS INFLAMABLES	12 in	300 mm
* MINIMUM DISTANCE TO NON-FLAMMABLE ELEMENTS DISTANCIA MÍNIMA A ELEMENTOS NO INFLAMABLES	4 in	100 mm

- 1 RECOMMENDED HOOD'S MINIMUM DIMENSIONS
MEDIDAS MÍNIMAS RECOMENDADAS DE LA CAMPANA EXTRACTORA.
- 2 RECOMMENDED CHEF'S WORKING SPACE
ESPACIO RECOMENDADO DE TRABAJO PARA EL CHEF.
- 3 RECOMMENDED HEIGHT TO INSTALL THE OVEN WITHOUT TABLE
ALTURA RECOMENDADA DE INSTALACIÓN DEL HORNO SIN MESA

Ed. 0602 - Jospers reserves the right to make modifications to catalogues, pricelists and promotional material according to the development and improvements applied to its equipment.
 Jospers se reserva el derecho a realizar modificaciones en los catálogos, tarifas y material de divulgación según evolución y mejora de sus equipos.

