



## HORNO BRASA JOSPER HJA-PLUS JOSPER CHARCOAL BROILER OVEN HJA-PLUS

# HJA-PLUS-S80-T

Los hornos de carbón vegetal Clase A incorporan un sistema hidráulico de retención de puerta para optimizar las maniobras del cocinero. Disponen de una area de templado superior que puede cerrarse con el accesorio disponible y una gama de mesas auxiliares opcionales.

Class A charcoal ovens incorporate a hydraulic door retention system to optimize the chef's maneuvers. They have an upper tempering area that can be closed with the available accessory and a range of optional auxiliary tables.

|   |                                 |
|---|---------------------------------|
| Recomendado para ±<br>Recommended for ±                                 | 80 comensales<br>80 dinners     |
| Tiempo de encendido<br>Fire up time                                     | 30 min aprox.<br>30 min average |
| Consumo diario de carbón<br>Charcoal daily consumption                  | 10 a 12kg<br>22 to 26.5 lb      |
| Autonomía por carga<br>Performance                                      | 9h                              |
| Producción por hora<br>Production per hour                              | 60 kg aprox.<br>132 lb average  |
| Temperatura de braseado<br>Broiling temperature                         | 250 a 350 °C<br>482 a 662 °F    |
| Capacidad bandejas GN (por parrilla)<br>Grill rack capacity in Gn trays | 1xGN1/1                         |
| Potencia térmica nominal<br>Nominal heat output                         | 8.8 kW<br>11.8 hp               |
| Caudal másico de humos<br>Flue gas mass flow                            | 19.36 g/s<br>0.68 oz/s          |
| Capacidad de extracción<br>Exhaust rate                                 | 2800 m³/h<br>1648 cfm           |
| Peso neto<br>Net weight   | -- kg<br>-- lb                  |



HJA-PLUS-S80-T

### ACCESORIOS INCLUIDOS INCLUDED ACCESSORIES

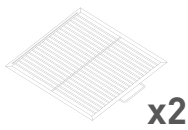

x2

Parrilla inox / Ref. [240024](#)  
Inox grill rack / Ref. [240024](#)

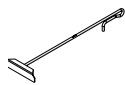

Atizador / Ref. [0401INOX](#)  
Poker / Ref. [0401INOX](#)

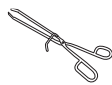

Pinzas Josper / Ref. [0423](#)  
Josper tongs / Ref. [0423](#)

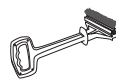

Cepillo metálico / Ref. [8224](#)  
Metallic brush / Ref. [8224](#)

\* Todos los productos Josper funcionan exclusivamente con carbón vegetal.  
All Josper products work exclusively with charcoal.

### MEDIDAS PARRILLA GRILL RACK MEASUREMENTS

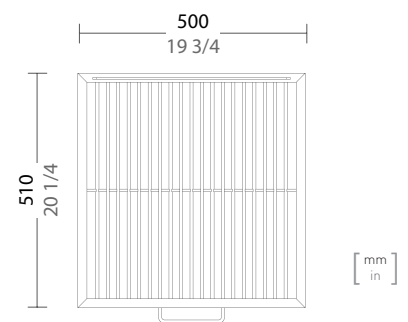

FT-C01150-05



# HJA-PLUS-S80-T

## INSTALACIÓN INSTALLATION

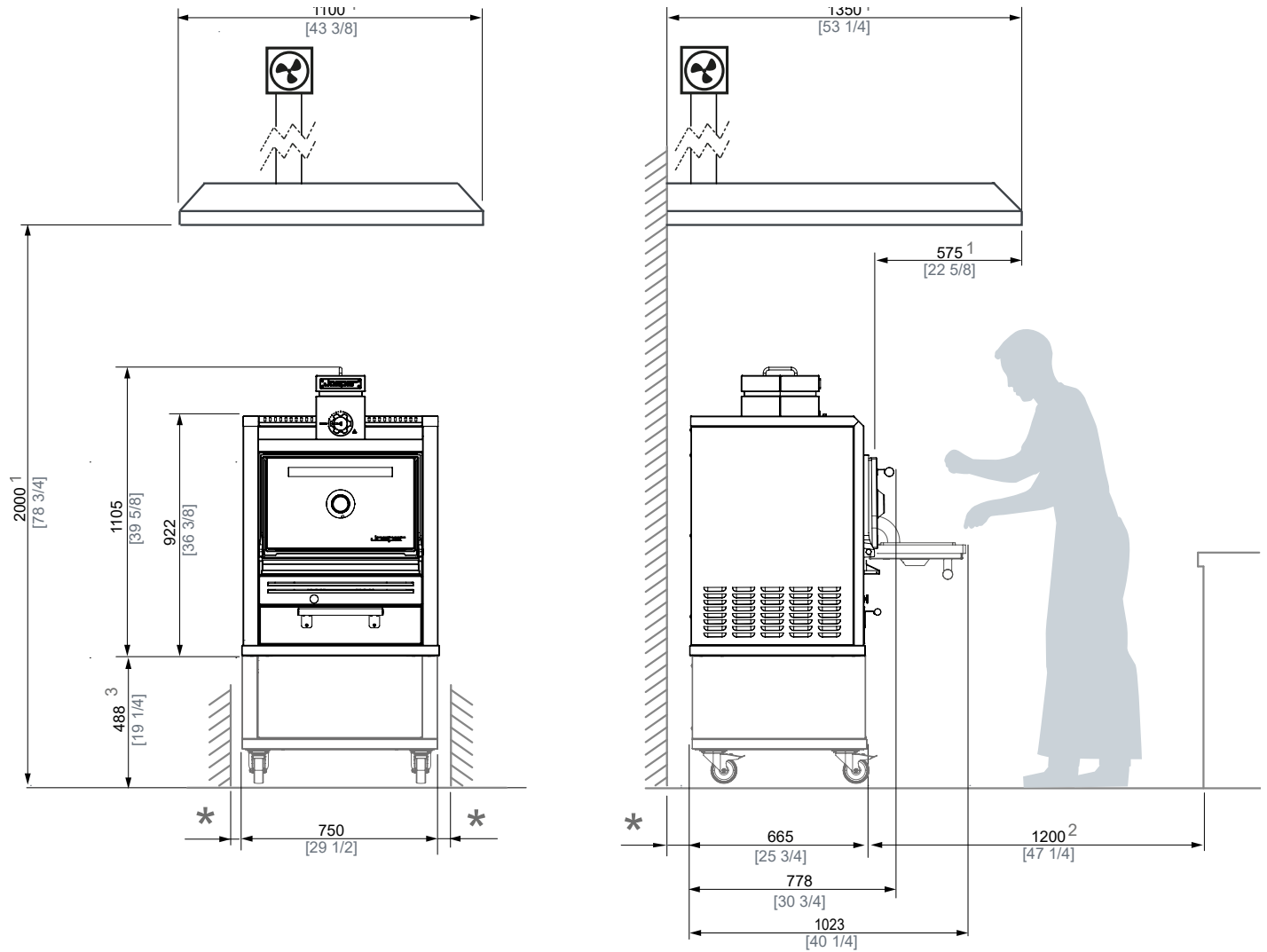

|  |        |       |
|--|--------|-------|
| * DISTANCIA MÍNIMA A ELEMENTOS INFLAMABLES<br>MINIMUM DISTANCE TO FLAMMABLE ELEMENTS     | 300 mm | 12 in |
| * DISTANCIA MÍNIMA A ELEMENTOS NO INFLAMABLES<br>MINIMUM DISTANCE TO FLAMMABLES ELEMENTS | 100 mm | 4 in  |

- 1 MEDIDAS MÍNIMAS RECOMENDADAS DE LA CAMPANA EXTRACTORA.  
RECOMMENDED HOOD'S MINIMUM DIMENSIONS
- 2 ESPACIO RECOMENDADO DE TRABAJO PARA EL CHEF.  
RECOMMENDED CHEF'S WORKING SPACE
- 3 ALTURA RECOMENDADA DE INSTALACIÓN DEL HORNO SIN MESA  
RECOMMENDED HEIGHT TO INSTALL THE OVEN WITOUT TABLE

Ed. 07.2022 - Jospser se reserva el derecho a realizar modificaciones en los catálogos, tarifas y material de divulgación según evolución y mejora de sus equipos.  
 Jospser reserves the right to make modifications to catalogues, pricelists and promotional material according to the development and improvements applied to its equipment.