



## HORNO BRASA JOSPER HJA-PLUS JOSPER CHARCOAL BROILER OVEN HJA-PLUS

# HJA-PLUS-S80

Los hornos de carbón vegetal Clase A incorporan un sistema hidráulico de retención de puerta para optimizar las maniobras del cocinero. Disponen de una area de templado superior que puede cerrarse con el accesorio disponible y una gama de mesas auxiliares opcionales.

Class A charcoal ovens incorporate a hydraulic door retention system to optimize the chef's maneuvers. They have an upper tempering area that can be closed with the available accessory and a range of optional auxiliary tables.

Recomendado para ± Recommended for ±	80 comensales 80 dinners
Tiempo de encendido Fire up time	30 min aprox. 30 min average
Consumo diario de carbón Charcoal daily consumption	10 a 12kg 22 to 26.5 lb
Autonomía por carga Performance	9h
Producción por hora Production per hour	60 kg aprox. 132 lb average
Temperatura de braseado Broiling temperature	250 a 350 °C 482 a 662 °F
Capacidad bandejas GN (por parrilla) Grill rack capacity in Gn trays	1xGN1/1
Potencia térmica nominal Nominal heat output	8.8 kW 11.8 hp
Caudal másico de humos Flue gas mass flow	19.36 g/s 0.68 oz/s
Capacidad de extracción Exhaust rate	2800 m³/h 1648 cfm
Peso neto Net weight	-- kg -- lb



HJA-PLUS-S80

### ACCESORIOS INCLUIDOS INCLUDED ACCESSORIES

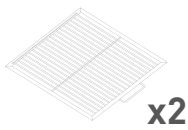

**x2**  
Parrilla inox / Ref. [240024](#)  
Inox grill rack / Ref. [240024](#)

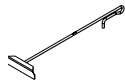

Atizador / Ref. [0401INOX](#)  
Poker / Ref. [0401INOX](#)



Pinzas Josper / Ref. [0423](#)  
Josper tongs / Ref. [0423](#)

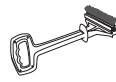

Cepillo metálico / Ref. [8224](#)  
Metallic brush / Ref. [8224](#)

\* Todos los productos Josper funcionan exclusivamente con carbón vegetal.  
All Josper products work exclusively with charcoal.

### MEDIDAS PARRILLA GRILL RACK MEASUREMENTS

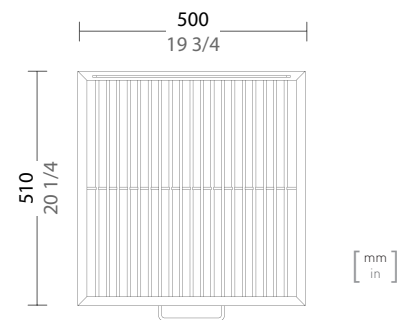

FT-C01125-05



# HJA-PLUS-S80

CONFIGURACIONES Y ACCESORIOS OPCIONALES  
 OPTIONAL CONFIGURATIONS & ACCESSORIES



**HJA-PLUS-S80-HC**

**HC - ARMARIO ATEMPERADOR** / Ref. [HC-45](#)  
**HC - HOT CAVINET** / Ref. [HC-45](#)



**HJA-PLUS-S80-T**

**T - MESA** / Ref. [200008](#)  
**T - TABLE** / Ref. [200008](#)



**HJA-PLUS-S80-TD**

**TD - MESA CON CAJÓN** / Ref. [200009](#)  
**TD - TABLE WITH DRAWER** / Ref. [200009](#)

INSTALACIÓN  
 INSTALLATION

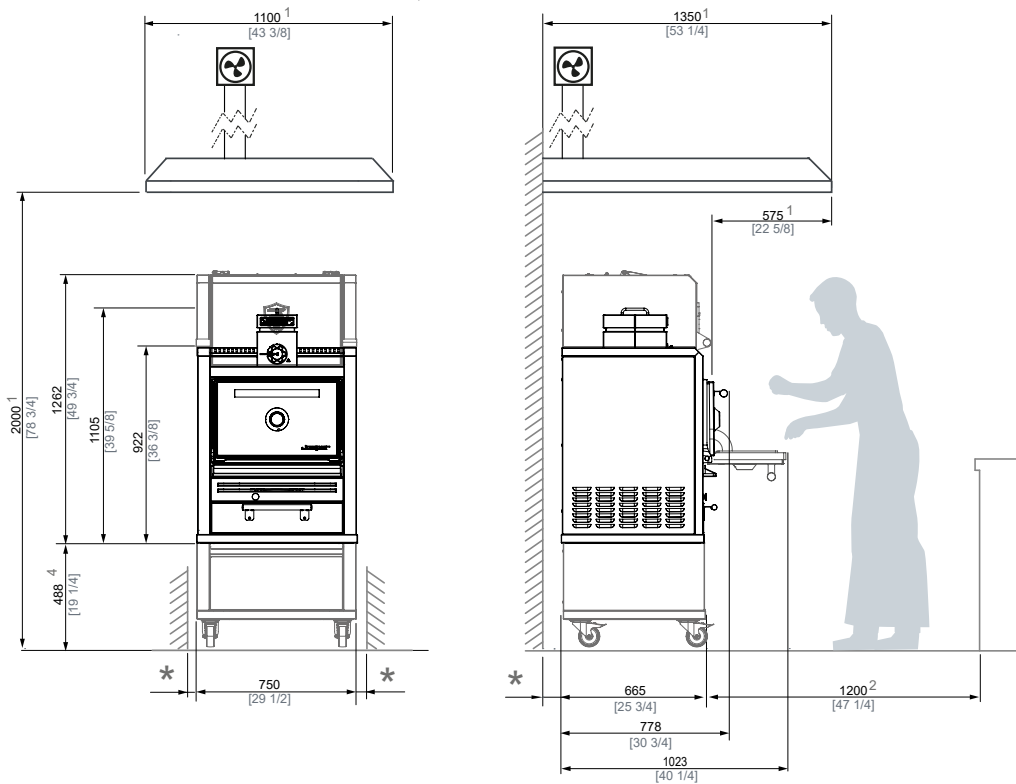

* DISTANCIA MÍNIMA A ELEMENTOS INFLAMABLES MINIMUM DISTANCE TO FLAMMABLE ELEMENTS	300 mm	12 in
* DISTANCIA MÍNIMA A ELEMENTOS NO INFLAMABLES MINIMUM DISTANCE TO FLAMMABLES ELEMENTS	100 mm	4 in

- 1 MEDIDAS MÍNIMAS RECOMENDADAS DE LA CAMPANA EXTRACTORA.  
RECOMMENDED HOOD'S MINIMUM DIMENSIONS
- 2 ESPACIO RECOMENDADO DE TRABAJO PARA EL CHEF.  
RECOMMENDED CHEF'S WORKING SPACE
- 3 ALTURA RECOMENDADA DE INSTALACIÓN DEL HORNO SIN MESA  
RECOMMENDED HEIGHT TO INSTALL THE OVEN WITHOUT TABLE

Ed. 07.2022 - Jospser se reserva el derecho a realizar modificaciones en los catálogos, tarifas y material de divulgación según evolución y mejora de sus equipos.  
 Jospser reserves the right to make modifications to catalogues, pricelists and promotional material according to the development and improvements applied to its equipment.