



## HORNO BRASA JOSPER HJA-PLUS JOSPER CHARCOAL BROILER OVEN HJA-PLUS

# HJA-PLUS-L175-T

Los hornos de carbón vegetal Clase A incorporan un sistema hidráulico de retención de puerta para optimizar las maniobras del cocinero. Disponen de una area de templado superior que puede cerrarse con el accesorio disponible y una gama de mesas auxiliares opcionales.

Class A charcoal ovens incorporate a hydraulic door retention system to optimize the chef's maneuvers. They have an upper tempering area that can be closed with the available accessory and a range of optional auxiliary tables.

Recomendado para ± Recommended for ±	175 comensales 175 dinners
Tiempo de encendido Fire up time	40 min aprox. 40 min average
Consumo diario de carbón Charcoal daily consumption	16 a 20kg 35 to 45 lb
Autonomía por carga Performance	9h
Producción por hora Production per hour	110 kg aprox. 242.5 lb average
Temperatura de braseado Broiling temperature	250 a 350 °C 482 a 662 °F
Capacidad bandejas GN (por parrilla) Grill rack capacity in Gn trays	2xGN1/1
Potencia térmica nominal Nominal heat output	9.6 kW 12.9 hp
Caudal másico de humos Flue gas mass flow	23.57 g/s 0.83 oz/s
Capacidad de extracción Exhaust rate	3800 m³/h 2237 cfm
Peso neto Net weight	-- kg -- lb



HJA-PLUS-L175-T

### ACCESORIOS INCLUIDOS INCLUDED ACCESSORIES

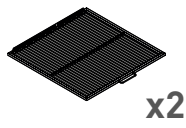

x2

Parrilla inox / Ref. [240026](#)  
Inox grill rack / Ref. [240026](#)

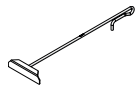

Atizador / Ref. [0427INOX](#)  
Poker / Ref. [0427INOX](#)



Pinzas Josper / Ref. [0423](#)  
Josper tongs / Ref. [0423](#)

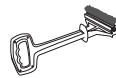

Cepillo metálico / Ref. [8224](#)  
Metallic brush / Ref. [8224](#)

\* Todos los productos Josper funcionan exclusivamente con carbón vegetal.  
All Josper products work exclusively with charcoal.

### MEDIDAS PARRILLA GRILL RACK MEASUREMENTS

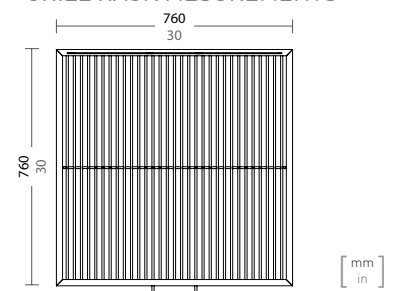

FT-C01150-05

# HJA-PLUS-L175-T

INSTALACIÓN  
 INSTALLATION

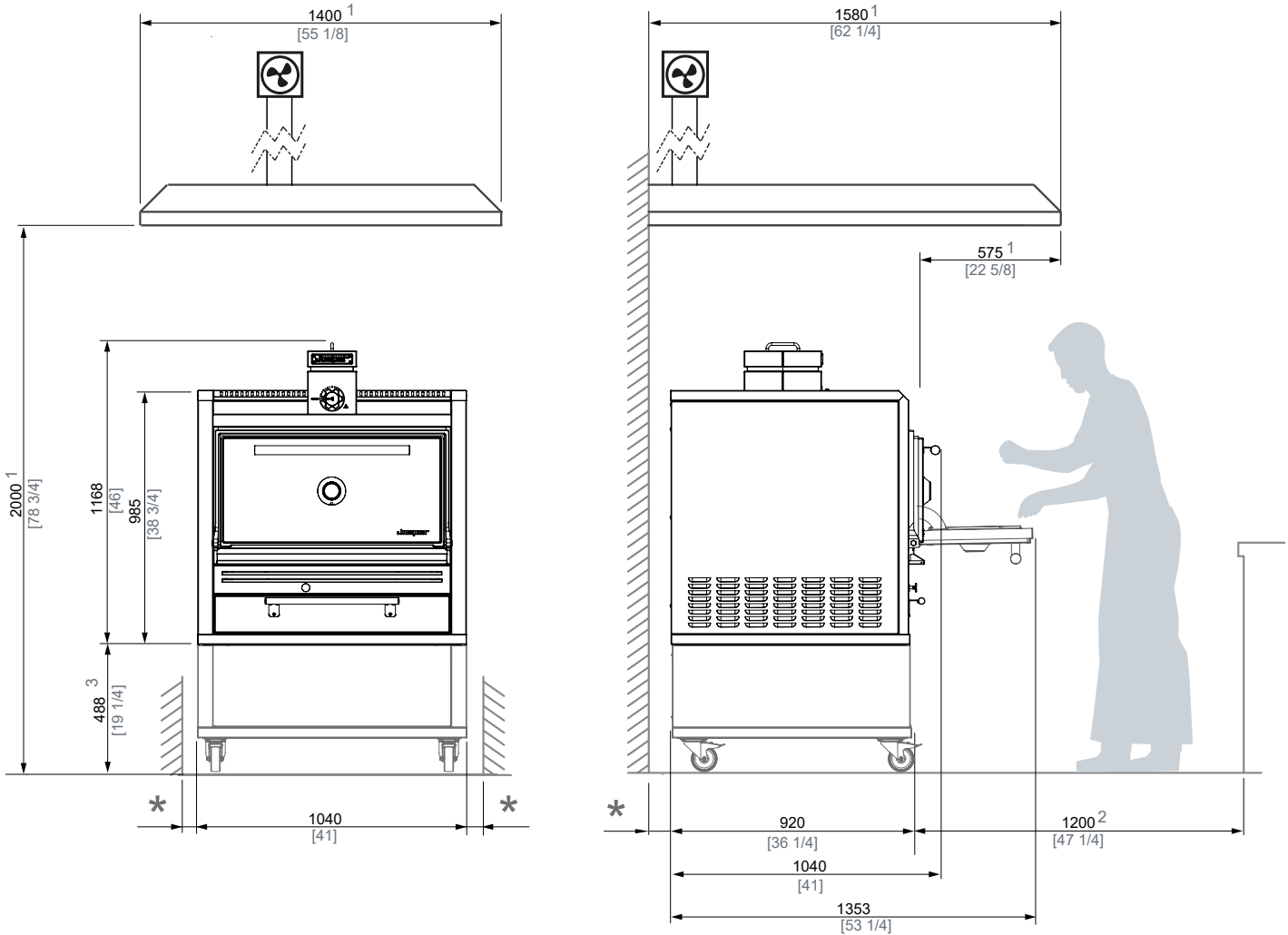

* DISTANCIA MÍNIMA A ELEMENTOS INFLAMABLES MINIMUM DISTANCE TO FLAMMABLE ELEMENTS	300 mm	12 in
* DISTANCIA MÍNIMA A ELEMENTOS NO INFLAMABLES MINIMUM DISTANCE TO FLAMMABLES ELEMENTS	100 mm	4 in

- 1 MEDIDAS MÍNIMAS RECOMENDADAS DE LA CAMPANA EXTRACTORA.  
RECOMMENDED HOOD'S MINIMUM DIMENSIONS
- 2 ESPACIO RECOMENDADO DE TRABAJO PARA EL CHEF.  
RECOMMENDED CHEF'S WORKING SPACE
- 3 ALTURA RECOMENDADA DE INSTALACIÓN DEL HORNO SIN MESA  
RECOMMENDED HEIGHT TO INSTALL THE OVEN WITOUT TABLE

Ed. 07.2022 - Josper se reserva el derecho a realizar modificaciones en los catálogos, tarifas y material de divulgación según evolución y mejora de sus equipos.  
 Josper reserves the right to make modifications to catalogues, pricelists and promotional material according to the development and improvements applied to its equipment.